



Department of
Building and Housing
Te Tari Kaupapa Whare

Guide to applying for a building consent (simple residential buildings)





Foreword

The building consent is the foundation document for any building project. It entitles you to carry out building work in accordance with the plans and specifications submitted in your consent application. It also provides formal recognition that your plans and specifications meet the requirements of the New Zealand Building Code, and therefore will be built to meet certain performance standards.

The Building Act 2004 increased the focus on the content and quality of the plans, specifications and documentation submitted for a building consent. Getting the design, planning and documentation right is the first step in ensuring a building can be built properly first time.

To build well, all parts of the building process need to work, from the initial design and building consent through to construction, inspection and ongoing maintenance. Measures in the Building Act are targeted at all parts of the building process. Those who design and build will be licensed. Councils and building consent authorities will be accredited and registered. Product manufacturers will be able to have their products certified under the product certification scheme.

The Building Code is under review to ensure performance standards for buildings are clear and meet people's needs.

This guide will help you prepare plans, specifications and documentation for a building consent application. Every building project is different and requires different documentation. Building consent authorities have their own systems for processing building consents, and the systems needed for a large metro building consent authority will remain different from those for a small rural one. Nevertheless, this guide aims to bring more consistency into the sector, and proposes a broad agreement on the form and content of building consent documentation.



John Kay
General Manager, Building Controls

ABOUT THIS DOCUMENT	3
INTRODUCTION	4
1.0 BACKGROUND	5
2.0 THE BUILDING CONSENT PROCESS	7
3.0 PLANS AND SPECIFICATIONS	8
4.0 DESIGN SUMMARY	12
5.0 DESIGN SUMMARY CHECK SHEET	15
6.0 DRAWINGS	21
6.1 Site plan	22
6.2 Foundation plan	24
6.3 Floor plan	26
6.4 Exterior elevations	28
6.5 Sections	30
6.6 Construction details	32
6.7 Additional drawings	34
7.0 RELATED ISSUES	35
8.0 APPLICATION FOR A PROJECT INFORMATION MEMORANDUM AND/OR BUILDING CONSENT	39
9.0 BUILDING INSPECTION REQUIREMENTS	40
10.0 PROJECT PLANNING	41
11.0 GLOSSARY OF TERMS	43

About this document

This guide has been prepared for people wishing to apply for a building consent for:

- simple residential buildings
- new buildings, primarily.

Readers are expected to have some knowledge of the Building Code and the building consent process.

WHO SHOULD READ THIS GUIDE?

This guide has been written to help designers, builders, homeowners' agents and developers by explaining the minimum information needed for a building consent application.

The information it contains may also be of interest to others in the construction sector, particularly product manufacturers, subcontractors, and providers of specialist technical services.

It is not generally intended as a guide for homeowner-applicants, because preparing documentation for consent applications, particularly for new building projects, requires a detailed knowledge of the Building Code and building process.

This document has been prepared by the Department of Building and Housing (the Department) as guidance information in accordance with section 175 of the Building Act.

The recommendations and suggestions in this guide are not mandatory and not intended to be prescriptive.

This guide is not a substitute for professional advice, and should not be relied on as establishing compliance with the Building Code. It is not a Compliance Document under the Building Act 2004, and may be updated from time to time. The latest version is available from the Department's website (www.dbh.govt.nz).

Introduction

The owner of a proposed building has the responsibility to make sure enough detail is provided in the plans, specifications and other documentation for the building consent authority to issue a building consent. Most applications for new building projects are completed on behalf of the owner by design professionals.

This guide focuses on how to obtain approval from a building consent authority. It will help you prepare plans, specifications and documentation for a building consent application. We have written it specifically for simple residential building work, such as new houses or townhouses. However, the principles it contains can be applied to all building projects.

The basic information needed for a building consent application is similar across New Zealand. However, each local council or building consent authority processes applications slightly differently, so there may be variations from one area to another.

For a building consent to be approved, you need to demonstrate how the proposed building will comply with the Building Code. It helps to remember that the Building Code sets out only the minimum performance standards a building must meet.

In many cases, homeowners and designers will strive for better standards.

It's also important to remember that the building consent authorities which approve applications are looking for compliance with the Building Code. It's not their role to design the work or to monitor quality and aesthetics, except where this affects compliance with the Building Code.

The documentation for even a simple new building project passes through many hands, including designers, builders, plumbers, drainlayers, homeowners and developers, and the building consent authority.

Good planning and documentation provides a solid foundation for everyone involved in the building process. It should speed up processing and approval times, and also provides an accurate historical record that can be used later when further work, repair or maintenance is needed.

Providing adequate documentation will help everyone involved in a building project play their part in ensuring the work is carried out properly, first time.

1.0 Background

1.1 THE BUILDING ACT 2004

The Building Act 2004 increased focus on the content and quality of plans and specifications submitted for a building consent.

Section 45 of the Building Act sets out in broad terms what an application for a building consent must contain. However, it does not define the form, content or quality of the plans and specifications, or other information needed to support an individual application.

The Building Act allows each building consent authority to determine what plans, specifications and other information it reasonably requires. This allows for differences to be managed locally, such as ways of storing and retrieving volumes of applications. However, it has led to inconsistency from one authority to another. This situation doesn't provide certainty for you or for building consent authorities.

We hope the approach set out in this guide will promote greater consistency and efficiency within the sector.

1.2 BUILDING CONSENT DOCUMENTATION

This guide includes recommendations on the appropriate form and minimum content for a building consent application. This includes the drawings, specifications and accompanying documents (other information), such as engineering calculations and design reports. This guide also discusses associated issues, such as the appropriate role of manufacturers' data, alternative design, engineering and design calculations, product appraisals, and various other forms of technical statement or warranty.

Some building consent authorities have specific requirements for building consent documentation, including:

- specific size, form and scale of individual drawings or the elements they contain
- requirements for certain line types, or thicknesses, or for lettering of a certain type or size.

Often these requirements are a result of the building consent authority's process for storing and retrieving building consent information (for example, digital storage). Although such requirements are not related to the Building Code or Building Act, it is useful to ask the building consent authority about any specific requirements it may have before lodging your building consent application.

1.3 COVERAGE OF DOCUMENTS

This guide focuses on information needed to confirm compliance with the Building Code. However, information on tendering, contractual issues, project management and construction, and on those parts of a building project not requiring Code compliance, can be included in a single set of documents suitable both 'for consent' and 'for construction'.

Building consent authorities may require other information, due to area-specific matters (such as known ground and environmental conditions), local district plan requirements, bylaws, or Local Government Act 2002 requirements. A project information memorandum (PIM) would identify any issues for you in advance.

1.4 ADDITIONS AND ALTERATIONS

You can also apply the principles and recommendations in this guide to projects involving additions and alterations to an existing building.

2.0 The building consent process

A building project starts on site after a building consent has been issued and concludes when a code compliance certificate is issued. Building consent authorities check that the documents submitted for a building consent confirm – in accordance with section 49(1) of the Building Act – ‘that the provisions of the Building Code would be met if the building work were properly completed in accordance with the plans and specifications that accompanied the application’.

Compliance with other requirements (such as bylaws or a district plan) may be critical to the design of the project, even though they’re not part of the building consent process. Therefore, you should consider these requirements as part of your project management and design.

Building consent authorities should not suspend building consent processing due to requests for further information or evidence on matters that fall outside compliance with the Building Code. This type of information is not part of the building consent process.

You will help the assessment process greatly if you ensure the building consent documentation:

- includes a clear summary or report explaining how compliance with each relevant clause of the Building Code will be achieved, including any waiver or modification sought (refer to section 4.0 of this guide)
- differentiates between items that relate to the Building Code and those that relate to contractual, tender and other Building Act requirements
- includes a schedule or schedules of the materials, products and systems (and their maintenance requirements) proposed to be used in constructing the building.

2.1 EARLY CONSULTATION IS IMPORTANT

Early consultation between you, your designer and the building consent authority plays an important role. It helps reduce misunderstandings at the time of application, as any specific document requirements from the building consent authority can be taken into account.

Obtaining a project information memorandum (PIM) early in the process may reveal useful information that helps the designer during their design work.

2.2 CODE COMPLIANCE CERTIFICATE

It’s important that all documentation relating to the building consent is complete, precise and is an accurate record of what has occurred on the site. The owner must apply for a code compliance certificate once the building work described in the building consent, with any subsequent approved amendments, has been completed.

The building consent authority must issue a code compliance certificate where it is satisfied that the building work complies with the building consent. Where the building consent authority is not satisfied, they may refuse to issue the code compliance certificate.

Sale by a residential property developer

Under section 364 of the Building Act, residential property developers (anyone building, or arranging to have built, a household unit for the purpose of selling it) must get a code compliance certificate before completing the sale, or allowing a purchaser to take possession of the household unit. The exception to this is when the property developer and buyer sign Form 1 of the Building (Forms) Regulations 2004. This form is called ‘Agreement between residential property developer and purchaser’. This form can’t be altered in any way.

3.0 Plans and specifications

3.1 DEFINITION

The Building Act defines 'plans and specifications' as 'the drawings, specifications and other documents according to which a building is proposed to be constructed, altered, demolished, or removed'.

This definition doesn't provide enough information for you to determine how much or how little detail is needed and how the information should be structured. Most building consent authorities will provide guidance on the documentation you need to submit with your building consent application forms (this may include check sheets).

You also need to consider any application information provided by the building consent authority.

For the purposes of this guide, 'other information' includes but is not limited to:

- calculations
- manufacturers' data
- technical opinions or appraisals
- codes of practice.

See section 7.0 of this guide for information on these subjects.

3.2 BUILDING CONSENT INFORMATION

Information in the plans and specifications needs to be project-specific.

Using general phrases such as 'refer to manufacturer's specification and/or requirements' or 'installed in accordance with best trade practice' is not sufficient. Manufacturers' specifications can change from time to time and 'best trade practice' is a standard that varies from individual to individual.

References to Standards and Compliance Documents need to be specific rather than general. Some Standards are cited (in whole or in part) in the Acceptable Solutions while other Standards offer advice only. Some Standards may also contain a range of options.

Make reference to any Standards that are readily available to those involved in the building process. References to other industry guides, such as BRANZ publications, need to be specific and not general.

References need to:

- uniquely identify documents with titles and dates
- be specific as to the paragraphs/clauses to be followed.

Compliance Documents and Acceptable Solutions

The Building Code, being performance-based, requires a certain level of performance to be achieved in buildings. Unlike prescriptive bylaws that existed before, it allows more than one way to achieve that performance. The Acceptable Solutions provided in the Compliance Documents (produced by the Department of Building and Housing) provide one means of demonstrating compliance with the Building Code. Building consent authorities must accept Compliance Documents as complying with the Building Code. Designers can provide an alternative solution, as long as they demonstrate to the building consent authority that the proposal will comply with the Building Code.

3.3 DRAWINGS

All drawings should contain a drawing number and title, the designer's and owner's name, and job address, and be dated for version control.

Drawing conventions – line types and widths, lettering type and size, symbols for building features and elements, designation of spaces, representation of materials and cross-referencing conventions – should generally conform to AS/NZS 1100 Technical Drawing. Either hand-drawn or CAD (computer-aided design) drawings are acceptable.

Drawing sizes may vary according to circumstance and convenience, usually ranging from A0 to A4. The size of drawing sheets should be consistent within a single set of project drawings. However, occasionally drawings or diagrams of components and construction details are more appropriately provided in A4 size and bound in with specification data (for example, a specific engineering detail).

The recognised Standard for architectural and engineering drawing in New Zealand is set out in different parts under AS/NZS 1100 Technical Drawing. This group of Standards provides useful advice on drawing conventions. While they do not provide a model for a typical set of building consent documents or construction documents, they nevertheless provide a good base to work from.

3.4 DRAWING RANGE

The size and complexity of the project often determines the level or amount of detail needed, and extent of associated structural and building services-related documents. You can find more detailed information on the form and content of drawings in section 6.0 of this guide.

3.5 DIMENSIONS

AS/NZS 1100.301 sets out conventions for dimensions on drawings. Where a finished dimension is critical for compliance or construction, you should clearly identify it in the relevant drawing or specification. Timber size should be identified by its actual finished size.

3.6 SPECIFICATION STRUCTURE

A good project specification has a logical structure and means of navigation. The default standard classification system for New Zealand is CBI (Coordinated Building Information), recognised by the 4-digit numbers used to classify each work section (ie, chapter) of the specification. There should be a 'Preliminaries' and a 'General' section, followed by a series of technical work sections, with each work section or chapter laid out in a consistent pattern (such as 'General', 'Products', 'Execution', 'Selections') and with a consistent clause numbering system.

Specifications have typically been based on proprietary model documents, or assembled by individual designers in a modified trade-based format. Specification sections have a long history of subdivision by trade (both traditional and influenced by NZS 4202: 1995 Standard Method of Measurement of Building Works) or work sections (based on CBI, a classification system modified from international practice by the Association for Coordinated Building Information New Zealand).

3.7 SPECIFICATION CONTENT

You should keep matters of tender, contract and project management separate from technical matters, and from the proposed product and material selections. You can describe product and material selections in each work section, grouped together in a single 'schedule', or list them on the drawings. A mix of trade-based, material-based, process-based and element-based sections or chapters is acceptable.

3.8 SPECIFICATIONS VERSUS DRAWINGS

Your specification should complement the drawings, not contain erroneous information and not contradict itself or associated documents. Information on drawings need not be in the specification and vice versa. Repeating the same information in two places may lead to contradiction and confusion, but may be useful for key points.

You should be able to decide how information is presented and where it is located. Reasonable requests made by the building consent authority should be respected.

Sometimes information on timber sizes and treatments is best placed on the drawings and sometimes the specification may be the preferred location. There will also be instances where project selections – such as sanitary fittings or door hardware – are best scheduled on the drawings, alongside details of cabinetwork or kitchen/bathroom fixtures. In other cases such selections may be better contained within the specification text.

You can also include certain drawn information in a specification, such as 'standard' details of a catch pit, or gully trap, a series of 'standard' reinforcing details, or items for fabrication off site. Wherever you give this information in the document set, it should be clear, correct and complete.

On a minor project, you can include the specification data on the drawings for the convenience of both the building consent authority and the builder.

3.9 GRAMMAR AND LANGUAGE

A consistent approach to grammar and language helps readability. Plain English and common words are preferred. Avoid legalese and jargon.

The future of documentation

Many designers are able to deliver, store and retrieve documents electronically. Some building consent authorities can also process and store building consent applications in electronic form. If you have suitable technology, you should ask the building consent authority if your application can be lodged electronically. Not only can this reduce the cost and inconvenience of exchanging information, it can also prevent problems with accessing and interpreting hard copy or scanned documents.

4.0 Design summary

A design summary is a tabulated listing of how you propose to comply with each of the relevant Building Code clauses. A design summary is not mandatory, but does have several benefits. It can:

- help the designer (during the documentation phase) and the building consent authority (during the building consent phase) by providing a checklist against compliance with the Building Code
- confirm which parts of the project are compliance-related, as opposed to construction- or contract-related only
- provide a checklist during construction, clarifying which changes will require a variation, amendment or a new building consent
- provide a useful checklist (where it is kept up to date) for the building consent authority to consider Code compliance after the project is complete.

How much information is needed?

The purpose of building consent documentation is to demonstrate, to the satisfaction of the building consent authority, that all relevant performance requirements of the Building Code are met. How extensive the plans, specifications and related information need to be depends on the complexity and size of the project and how closely the design conforms with Acceptable Solutions or Verification Methods in the Compliance Documents for the Building Code. In some cases, you may need to describe how Code compliance is achieved for individual building elements where the element must comply with a variety of Code clauses (for example, a boundary wall that is fire-rated, provides bracing, has sound-control properties and is located in a wet area).

4.1 COMPLIANCE WITH BUILDING CODE CLAUSES

Take care to ensure all relevant clauses of the Building Code are correctly identified and considered during the design process. They need to be identified on the building consent application form where appropriate (see section 8.0 of this guide). If you use a design summary, you could make specific reference to the relevant clause of the Building Code.

The relevant Building Code clauses for simple, residential buildings are described below. However, in each particular case you should consult the Building Code to check that the relevant performance criteria have been met.

B1 Structure – demonstrating how the building withstands likely loads, including wind, earthquake, live and dead loads (people and building contents).

B2 Durability – confirming the use of materials that will remain functional for the minimum periods specified (5, 15 or at least 50 years).

C Fire Safety – demonstrating means of escape and boundary separations.

D1 Access Routes – the safety of entry/exit to the building and the safety of any internal or external stairs and slip resistance.

E1 Surface Water – the method of disposal of, for example, rainwater from external surfaces, and confirmation that surface water cannot enter the building.

E2 External Moisture – confirming that the design and detailing of all external roof and wall claddings and external openings will prevent external moisture from causing undue dampness or damage.

E3 Internal Moisture – confirming that surfaces in wet areas are durable enough, easily cleaned and designed to resist moisture, and that ventilation and the space temperature are sufficient to avoid the excessive build-up of moisture.

F1 Hazardous Agents on Site – identifying and neutralising any hazardous agents or other contamination of the building site.

F2 Hazardous Building Materials – confirming the appropriate selection of glass and glazing methods to ensure the safety of building users. It also considers building materials that give off noxious fumes.

F4 Safety from Falling – confirming the safe design of all barriers (including handrails and balustrades) inside and outside the building (note: includes the design of swimming pool fences under the Fencing of Swimming Pools Act 1987).

G1 Personal Hygiene – providing sufficient sanitary fixtures (toilets, showers and basins) for cleanliness.

G2 Laundering – providing sufficient laundry facilities.

G3 Food Preparation and Prevention of Contamination – providing sufficient safe and hygienic facilities for food storage and preparation.

G4 Ventilation – confirming required natural or forced ventilation to all occupied spaces.

G7 Natural Light – confirming that sufficient natural light is provided to occupied spaces and providing appropriate visual awareness for the occupants.

G8 Artificial Light – confirming the provision of minimum light levels in occupied spaces.

G9 Electricity – confirming safe distribution and use of electricity.

G10 Piped Services – confirming the safe distribution of gas.

G11 Gas as an Energy Source – confirming the safe installation of gas-powered appliances.

G12 Water Supplies – confirming the safe supply (avoidance of scalding and backflow), storage, reticulation and, where needed, heating of potable water.

G13 Foul Water – confirming the safe and sanitary collection and disposal of foul water and the prevention of foul air from entering the building.

H1 Energy Efficiency – confirming the provision of a warm, dry interior environment through insulation and controlling air movement, and the efficient use of energy.

4.2 GENERAL COMPLIANCE ISSUES

Simply stating that a project complies with the Building Code is not sufficient. You need to show **how** the project complies. For example, for a simple residential building the performance requirements of Clauses B1 and B2 can be achieved by demonstrating compliance with NZS 3604 Timber Framed Buildings and NZS 3602 Timber and Wood Based Products for Use in Building, which are referenced in B1/AS1 and B2/AS1 of the B1 and B2 Compliance Documents respectively.

Where a part of the design does not comply with the chosen Acceptable Solution, you will need to demonstrate how that particular element or part element complies with the Building Code.

Using general details or a general statement of compliance with the Building Code in the specification is not sufficient to demonstrate compliance. The drawings and the details they contain must be specific to the project. You should clearly identify in the specification the particular materials and/or systems you intend to use.

Manufacturers' information

The Acceptable Solutions and Verification Methods in the Compliance Documents do not reference specific branded products or systems. However, brand-specific products and systems can be proposed to demonstrate compliance with the Building Code. Once the building consent has been issued, any changes to the specific products or systems named in the application will need to be approved by the building consent authority.

Where a product is not needed to achieve compliance with the Building Code, you may describe it generically.

Manufacturers should, as a matter of good practice, ensure the data sheets they provide to designers, specifiers and builders are clearly dated and include only relevant technical data on the selected material or product. Be mindful that some materials and products contain mixed technical and marketing data. (Refer to AS/NZS 1388 Guidelines for Technical Information for Building and Construction Products.)

5.0 Design summary check sheet

When completing the building consent application form (Form 2) you must show how the building design proposes to meet the requirements of each relevant clause of the Building Code. The table below shows some of the more common methods used to establish compliance with the Building Code.

DESIGN SUMMARY CHECK SHEET									
Note:	<p>Select your proposed means of compliance against each of the relevant Building Code clauses by ticking the relevant box or boxes, or by specifying another means of compliance under 'Other'.</p> <p>Then provide details of the specific means of compliance by listing the products, systems and/or the methods used in the plans and specifications to confirm compliance.</p> <p>Refer to the introductory notes for advice on the issues needing to be addressed under each Building Code clause.</p>								
Project description:	<i>(Example: Two-storey, timber-framed building. Timber-trussed roof, timber-framed first floor, concrete slab on grade.)</i>								
Project information:	<p>Owner's or agent's name:</p> <p>Contact details:</p> <p>Designer's name(s):</p> <p>Contact details:</p> <p>Site address:</p> <p>Deposited plan:</p> <p>Lot number:</p>								
Site data:	<table border="1"> <tr> <td><i>Soil type (NZS 3604, clause 3.2)</i></td> <td><i>(Example: good ground)</i></td> </tr> <tr> <td><i>Exposure/corrosion zone (NZS 3604, figures 4.1, 4.2)</i></td> <td><i>(Example: Zone 3)</i></td> </tr> <tr> <td><i>Wind zone (NZS 3604, tables 5.1, 5.2)</i></td> <td><i>(Example: R1/Urban/Sheltered/Low)</i></td> </tr> <tr> <td><i>Earthquake zone (NZS 3604, figure 5.4)</i></td> <td><i>(Example: Zone C)</i></td> </tr> </table>	<i>Soil type (NZS 3604, clause 3.2)</i>	<i>(Example: good ground)</i>	<i>Exposure/corrosion zone (NZS 3604, figures 4.1, 4.2)</i>	<i>(Example: Zone 3)</i>	<i>Wind zone (NZS 3604, tables 5.1, 5.2)</i>	<i>(Example: R1/Urban/Sheltered/Low)</i>	<i>Earthquake zone (NZS 3604, figure 5.4)</i>	<i>(Example: Zone C)</i>
	<i>Soil type (NZS 3604, clause 3.2)</i>	<i>(Example: good ground)</i>							
	<i>Exposure/corrosion zone (NZS 3604, figures 4.1, 4.2)</i>	<i>(Example: Zone 3)</i>							
	<i>Wind zone (NZS 3604, tables 5.1, 5.2)</i>	<i>(Example: R1/Urban/Sheltered/Low)</i>							
<i>Earthquake zone (NZS 3604, figure 5.4)</i>	<i>(Example: Zone C)</i>								

DESIGN SUMMARY CHECK SHEET (CONTINUED)

Building data:	<i>Building category (NZS 3604, table 1.1)</i>	<i>(Example: IV/Domestic)</i>	
	<i>Floor live loads (NZS 3604, table 1.2)</i>	<i>(Example: Generally 1.5 kPa, Balconies and decks 2.0 kPa)</i>	
	<i>Overall height of building (NZS 3604)</i>	<i>(Example: 8 metres)</i>	
BUILDING CODE CLAUSE: <i>Indicate which of the following clauses are involved in the work.</i>	COMPLIANCE USING: <i>AS or VM, or Standards, or identify the other documents used to establish compliance</i>	COMPLIANCE USING: <i>Identify if using:</i> <ul style="list-style-type: none"> • <i>product certification (Codemark)</i> • <i>specific design</i> • <i>producer statement (chartered professional engineer or other engineer)</i> • <i>licensed trade (electrical/gasfitting)</i> • <i>other (specify)</i> 	SPECIFIC MEANS OF COMPLIANCE: <i>Provide details of products and systems and/or the methods used in the plans and specifications to confirm compliance with the nominated approach.</i>
B1 Structure	<input type="radio"/> B1/AS1 <input type="radio"/> B1/VM1 <input type="radio"/> B1/AS2 <input type="radio"/> B1/AS3 <input type="radio"/> NZS 3603 <input type="radio"/> NZS 3604 <input type="radio"/> NZS 3622 <input type="radio"/> NZS 4203 <input type="radio"/> NZS 4229 <input type="radio"/> NZS 4251		

DESIGN SUMMARY CHECK SHEET (CONTINUED)

BUILDING CODE CLAUSE:	COMPLIANCE USING:	COMPLIANCE USING:	SPECIFIC MEANS OF COMPLIANCE:
B2 Durability	<input type="radio"/> B2/AS1 <input type="radio"/> NZS 3101 <input type="radio"/> NZS 3602 <input type="radio"/> NZS 3604 <input type="radio"/> NZS 4251		
C1 Outbreak of Fire	<input type="radio"/> C/AS1		
C2 Means of Escape			
C3 Spread of Fire			
C4 Structural Stability During Fire			
D1 Access Routes	<input type="radio"/> D1/VM1 <input type="radio"/> D1/AS1 <input type="radio"/> NZS 4121		
E1 Surface Water	<input type="radio"/> E1/AS1 <input type="radio"/> NZS 4452 <input type="radio"/> AS/NZS 3500.3 <input type="radio"/> E1/VM1		

DESIGN SUMMARY CHECK SHEET (CONTINUED)

BUILDING CODE CLAUSE:	COMPLIANCE USING:	COMPLIANCE USING:	SPECIFIC MEANS OF COMPLIANCE:
E2 External Moisture	<input type="radio"/> E2/VM1 <input type="radio"/> E2/AS1		<input type="radio"/> Risk matrix
E3 Internal Moisture	<input type="radio"/> E3/AS1		
F1 Hazardous Agents on Site			
F2 Hazardous Building Materials	<input type="radio"/> F2/AS1 <input type="radio"/> NZS 4223		
F4 Safety from Falling	<input type="radio"/> F4/AS1 <input type="radio"/> Fencing of Swimming Pools Act 1987		
G1 Personal Hygiene	<input type="radio"/> G1/AS1		
G2 Laundering	<input type="radio"/> G2/AS1		
G3 Food preparation and Prevention of Contamination	<input type="radio"/> G3/AS1		

DESIGN SUMMARY CHECK SHEET (CONTINUED)

BUILDING CODE CLAUSE:	COMPLIANCE USING:	COMPLIANCE USING:	SPECIFIC MEANS OF COMPLIANCE:
G4 Ventilation	<input type="radio"/> G4/AS1 <input type="radio"/> NZS 4303 <input type="radio"/> AS 1668.2		
G5 Interior Environment	<input type="radio"/> G5/AS1		
G7 Natural Light	<input type="radio"/> G7/AS1		
G8 Artificial Light	<input type="radio"/> G8/VM1 <input type="radio"/> G8/AS1 <input type="radio"/> NZS 6703		
G9 Electricity	<input type="radio"/> G9/AS1	<input type="radio"/> Registered electrician (energy work certificate supplied on completion)	
G10 Piped Services	<input type="radio"/> G10/AS1 <input type="radio"/> NZS 5261 <input type="radio"/> G10/VM1	<input type="radio"/> Registered gasfitter	
G11 Gas as an Energy Source	<input type="radio"/> G11/AS1 <input type="radio"/> NZS 5261	<input type="radio"/> Registered gasfitter (energy work certificate supplied on completion)	

DESIGN SUMMARY CHECK SHEET (CONTINUED)

BUILDING CODE CLAUSE:	COMPLIANCE USING:	COMPLIANCE USING:	SPECIFIC MEANS OF COMPLIANCE:
G12 Water Supplies	<input type="radio"/> G12/AS1 <input type="radio"/> AS/NZS 3500.5	<input type="radio"/> Engineer <input type="radio"/> Registered plumber	
G13 Foul Water	<input type="radio"/> G13/AS1 <input type="radio"/> AS/NZS 3500.5	<input type="radio"/> Engineer <input type="radio"/> Registered plumber <input type="radio"/> Registered drainlayer	
H1 Energy Efficiency	<input type="radio"/> H1/AS1 <input type="radio"/> NZS 4218 <input type="radio"/> ALF design manual	<input type="radio"/> Engineer	
List proposed owner inspections (identify the aspects of work proposed to be inspected by the designer and/ or engineer).			

6.0 Drawings

This section includes examples of the following types of construction drawings.

6.1 **SITE PLAN**

6.2 **FOUNDATION PLAN**

6.3 **FLOOR PLAN**

6.4 **EXTERIOR ELEVATIONS**

6.5 **SECTIONS**

6.6 **CONSTRUCTION DETAILS**

The descriptions are not exhaustive but are typical of what is required in the drawings. Some of the information recommended in the following drawings is not related to the Building Code but will help the territorial authority to determine whether the work breaches or needs approval under other legislation, such as bylaws or the Resource Management Act. Additional information of this type is shown in text boxes.

6.1 Site plan

The purpose of a site plan is to show the dimensions and form of the site, the proposed building work, and where on the site the building will be located. You should also include any known information on existing and proposed services.

Drainage information in a diagrammatic form could be included on the site plan. This should show both existing and new stormwater, sewer and relief drainage pipework and fittings. You should also detail how you propose that these services will connect with the network utility operators' systems, or can discharge into an approved on-site drainage system (soakage and/or treatment).

Additional information

Show distances from building work to boundaries, and include a north point.

It's helpful to include the site's legal description, building area (in square metres) and site area.

When preparing the plan, check with the building consent authority and network utility operators for information on the location of existing services both to and across the site.

Include a site datum. This may be a manhole cover or similar on the site or in the street. The builder may need to establish and maintain a new site datum.

Including calculations for site coverage on the site plan will help the territorial authority determine compliance with district plan requirements.

DRAWING TYPE (Note 1)	RECOMMENDED SCALE	MINIMUM RECOMMENDED DETAIL (Note 2)
Site plan (Note 3)	1:200 (Note 4)	<ul style="list-style-type: none"> • Legal description, legal boundaries and any easements. • North point. • Building location, including dimensions in metres to boundaries, and boundary fire ratings. • Spot levels or contours and site datum. • Location of existing and new services (water, power, gas, stormwater, foul water). • Proposed/actual driveway, site finishes (hard and soft) with levels and falls. • Excavation details (cut and fill) and retaining walls. • Existing buildings and site features. • Identify natural hazards (where known). • Identify vehicle crossing(s).

Note 1 Drawings may be combined.

Note 2 Requirements may differ where the building project is an alteration or addition to an existing building.

Note 3 For rural and/or larger sites a 1:500 (or 1:1000) location plan may be needed to confirm the site location.

Note 4 A scale of 1:500 or 1:100 may be adequate in some cases.

Sample only

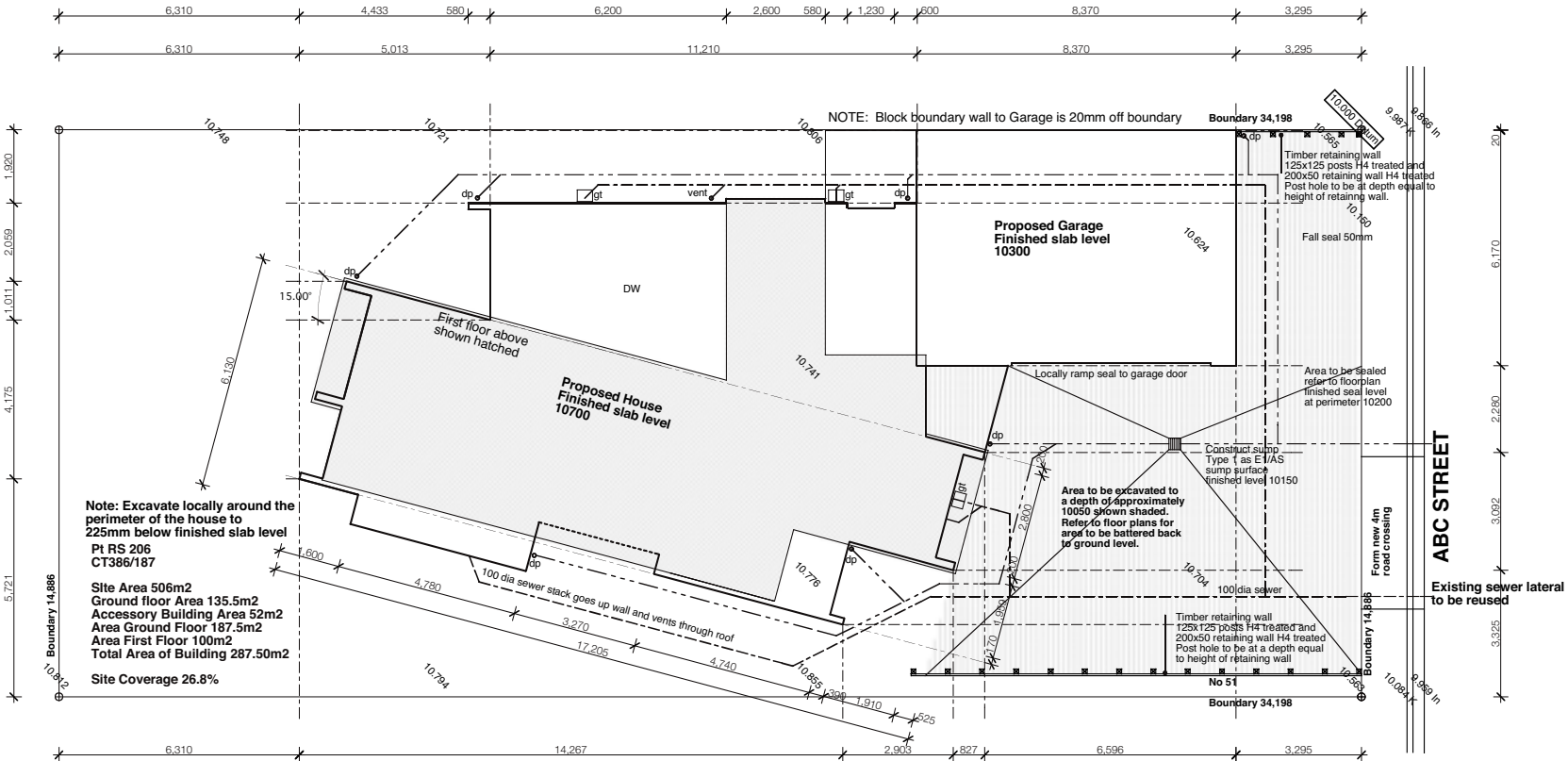

CLIENT _____

CONTRACTOR _____

CONSULTANTS _____

PROPOSED NEW DWELLING
ABC STREET
City field empty

SITE PLAN

SCALE 1:100

DATE 02 February 06

JOB No. 0712

DRAWN CH

CHECKED KR

STATUS CONSENT

DRAWING No. A01 REVISION (A)

Note: Excavate locally around the perimeter of the house to 225mm below finished slab level
 Pt RS 206
 CT386/187

Site Area 506m²
 Ground floor Area 135.5m²
 Accessory Building Area 52m²
 Area Ground Floor 187.5m²
 Area First Floor 100m²
 Total Area of Building 287.50m²
 Site Coverage 26.8%

SITE PLAN
 Scale 1:100

Note: existing ground levels shown thus 10.748

6.2 Foundation plan

The purpose of the foundation plan is to show the building consent authority and the practitioner or constructor what type(s) of foundation you propose, and to detail their individual dimensions.

Additional information

The plan should include the finished floor height(s) in relation to the site datum. Where the property is located in a flood zone, confirm the relationship between the site datum and the minimum occupied floor level set by the territorial authority in the district plan.

Where foundations are designed by a registered engineer, supporting information should be provided, including calculations, design assumptions (eg, soil bearing) and possibly a producer statement for design. You should identify details of inspections and tests to be carried out by the design engineer on the building consent application under the heading 'Proposed owner inspections'.

DRAWING TYPE (Note 1)	RECOMMENDED SCALE	RECOMMENDED DETAIL (Note 2)
Foundation plan	1:100 (Note 3)	<ul style="list-style-type: none"> • Concrete slab dimensions and thickenings (where applicable). • Foundation walls. • Pile layout with dimensions, pile type bearer sizes (including for decks and pergolas). • Subfloor bracing layout. • Subfloor ventilation (or show on elevations). • Floor framing layout (optional) (Note 4). • Specific design foundations.

Note 1 Drawings may be combined.

Note 2 Requirements may differ where the building project is an alteration or addition to an existing building.

Note 3 A scale of 1:50 may be needed where foundations are relatively complex.

Note 4 Provided it is clear as to what is required, it may not be necessary to show each and every floor joist.

Sample only

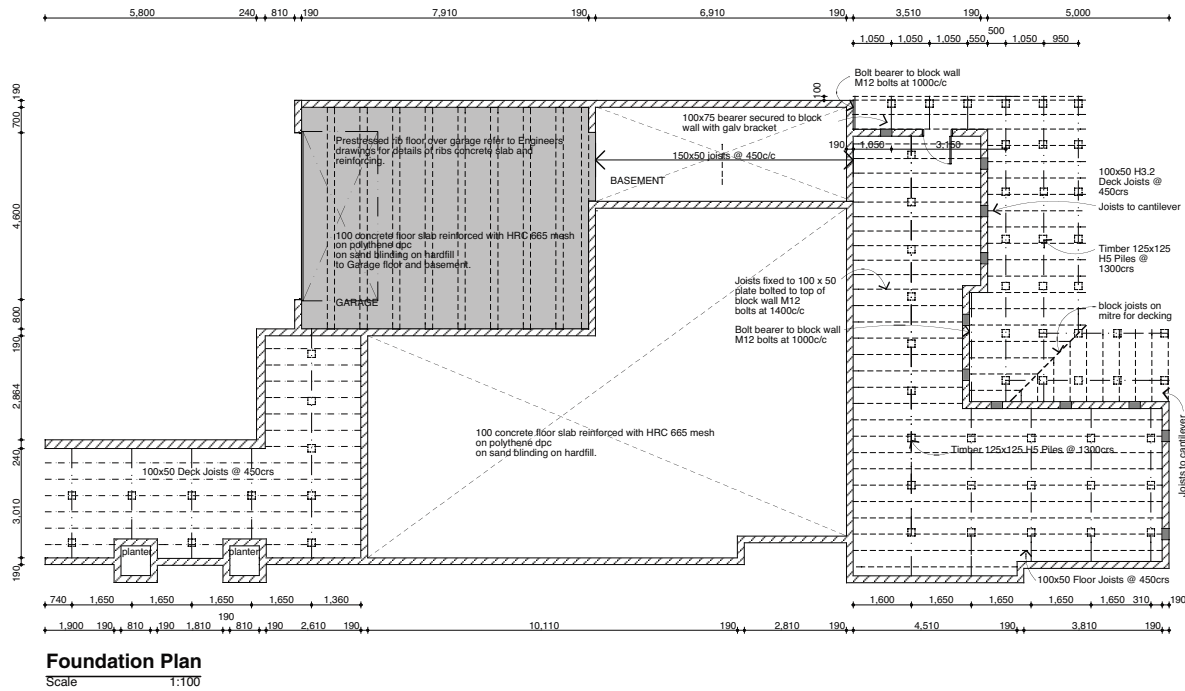

SCHEDULE OF TIMBER TREATMENT

- H1.1** Framing protected from the weather and above ground (not sub-floor framing)
 - Roof and ceiling framing
 - Roof trusses / purlins
 - Low risk interior wall framing
 - Intermediate interior floor framing
- H1.2** Framing protected from the weather, above ground with the possibility of exposure to moisture.
 - Skillion roof above 10° framing with lined soffits
 - Exterior walls protected from the weather
 - Wall framing
 - Subfloor framing except piles
- H3.1** Framing exposed to intermittent moisture, above ground but protected from the weather by an approved paint system or cladding.
 - Wall and floor framing to at risk wet areas
 - Floor framing below 10°
 - Exterior painted posts and beams
 - Enclosed linets and posts supporting enclosed balconies
 - Enclosed balcony ply and joists
 - Balustrade framing
 - Cavity battens
- H3.2** Framing exposed to the weather above ground with a risk of trapped water.
 - External rafters and beams
 - Timber slatted decking joists and bearers
 - Fence palling and rails not in contact with ground
- H5** Timber in contact with the ground
 - Piles

CLIENT

CONTRACTOR

CONSULTANTS

PROPOSED NEW DWELLING
123 ABC STREET

Foundation and Sub floor
Framing Plan

SCALE

DATE 28 February 06

JOB No. 07123

DRAWN

CHECKED

STATUS

Construction

DRAWING No.

REVISION

04

X

6.3 Floor plan

The purpose of the floor plan(s) is to provide details of room types and sizes, the layout and location of the internal elements, and the location of all fixtures and fittings.

Additional information

Show and describe the bracing elements and lintels on the floor plan. Where floor plans are complex, use a separate key plan containing just the critical structural information, such as bracing elements and lintels, to avoid cluttering the floor plans.

Provide reference numbers for all windows and doors shown on the plans that may be scheduled elsewhere on the drawing set, or in the specification.

Separate electrical plans, detailing electrical fixtures and fittings, are sometimes justified. Show any installations related to the building consent, such as smoke alarms and ventilation fans.

Where the building work is an addition or alteration to an existing building, the floor plan should clearly distinguish between the proposed new and the existing building work.

DRAWING TYPE (Note 1)	RECOMMENDED SCALE	RECOMMENDED DETAIL (Note 2)
Floor plan(s)	1:50 (Note 3)	<ul style="list-style-type: none"> • Floor levels relative to the site datum. • Overall dimensions of walls and other structural elements. • Internal dimensions of rooms. • Bracing layout or reference to a schedule elsewhere. • Lintel sizes or reference to a schedule elsewhere. • Window and door locations and plan dimensions. • Special wall constructions (sound, fire, moisture control). • Room layouts and location of all internal fixtures and fittings. • Staircase layouts. • Plumbing diagram and location of plumbing fixtures. • Cross-section references, space numbers, door/window numbers. • References to detailed drawings. • Outline of roof or pergola overhangs. • Electrical fittings needed for compliance. • Concrete slab reinforcing details and construction joints (if not shown on the foundation plan). • Openings for services.

Note 1 Drawings may be combined.

Note 2 Requirements may differ where the building project is an alteration or addition to an existing building.

Note 3 A scale of 1:100 may be adequate for a simple project. A separate plan must be provided for each level of the building. Where the lower floor is timber framed, a foundation plan will be needed to clarify the foundation layout (see section 6.2 of this guide).

Sample only

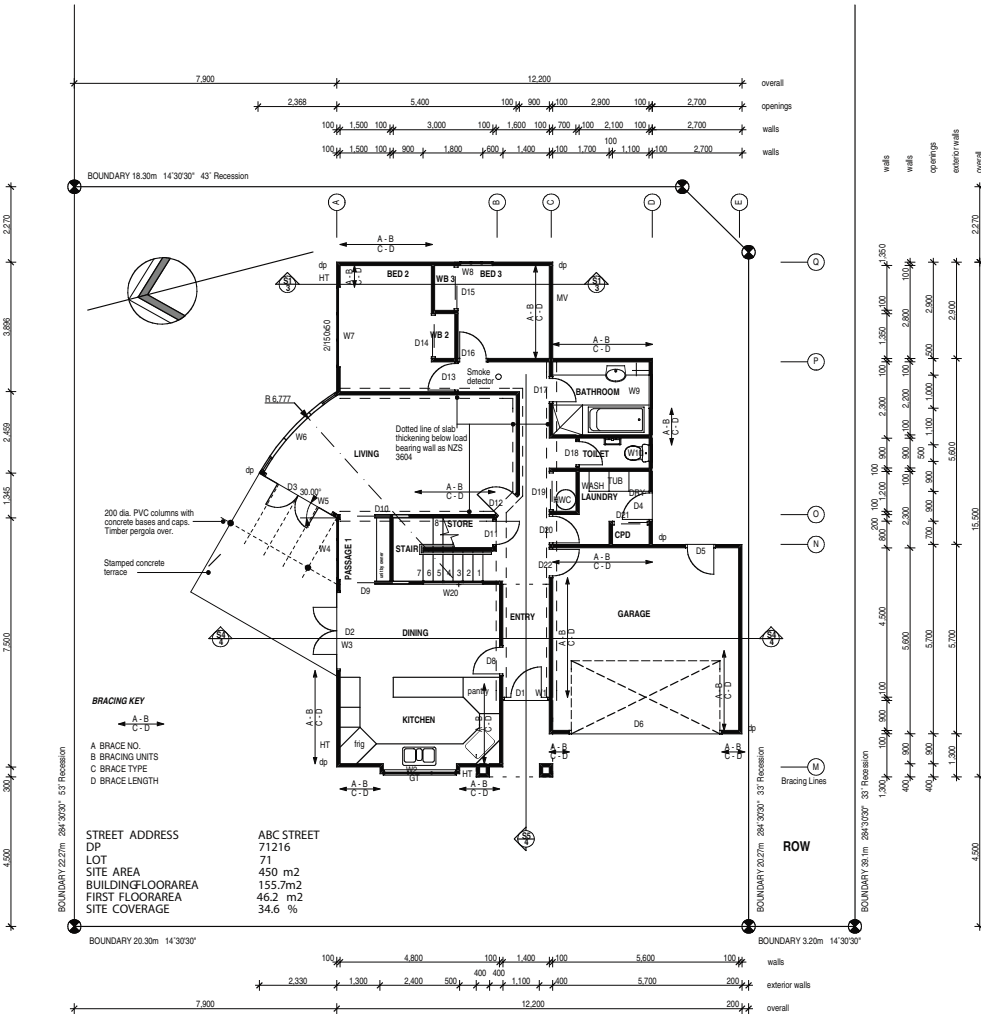

22 ABC STREET

GROUND FLOOR PLAN
 Scale 1:100

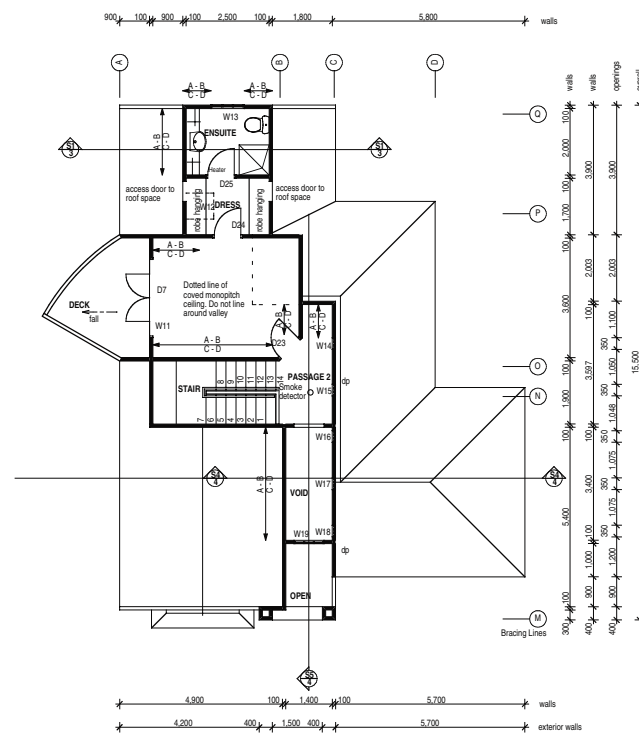

FIRST FLOOR PLAN
 Scale 1:100

CLIENT _____

CONTRACTOR _____

CONSULTANTS _____

PROPOSED NEW DWELLING
ABC STREET

FLOOR PLANS

SCALE _____
 DATE 28 February 06
 JOB No. 0666
 DRAWN _____
 CHECKED _____
 STATUS Consent
 DRAWING No. _____ REVISION
A02 (A)

6.4 Exterior elevations

The purpose of exterior elevations is to show the overall shape, form and size of the proposed building. In addition, it needs to show the location, form and finish of exterior elements, including wall claddings, roof claddings, window and door locations, and the location of specific elements, such as decks, stairs, downpipes and vents, and wall and roof openings.

Additional information

Include ground lines (existing and finished) and heights of building elements relative to the site datum.

Extending ground lines through to adjacent boundaries, showing maximum height to boundary angles (sunlight access planes), will help the territorial authority confirm compliance with planning requirements.

DRAWING TYPE (Note 1)	RECOMMENDED SCALE	RECOMMENDED DETAIL (Note 2)
Elevations	1:100 (Note 3)	<ul style="list-style-type: none"> • All exterior elevations of the building. • Relative levels, overall height of dwelling. • Windows, doors and other openings, indicating size and opening type and direction. • Cladding types. • Roofing types, roof shapes and overhangs. • Exterior decks, stairs and balustrades. • Skylights, chimneys and other openings through walls and roof. • Gutter, downpipe and vent locations. • Location of construction joints in claddings. • References to detailed drawings. • Reference to risk matrix (Note 4).

Note 1 Drawings may be combined.

Note 2 Requirements may differ where the building project is an alteration or addition to an existing building.

Note 3 Increase to 1:50 minimum scale where exterior openings are not scheduled elsewhere.

Note 4 Refer to the Department of Building and Housing guide *External moisture – A guide to using the risk matrix*.

Sample only

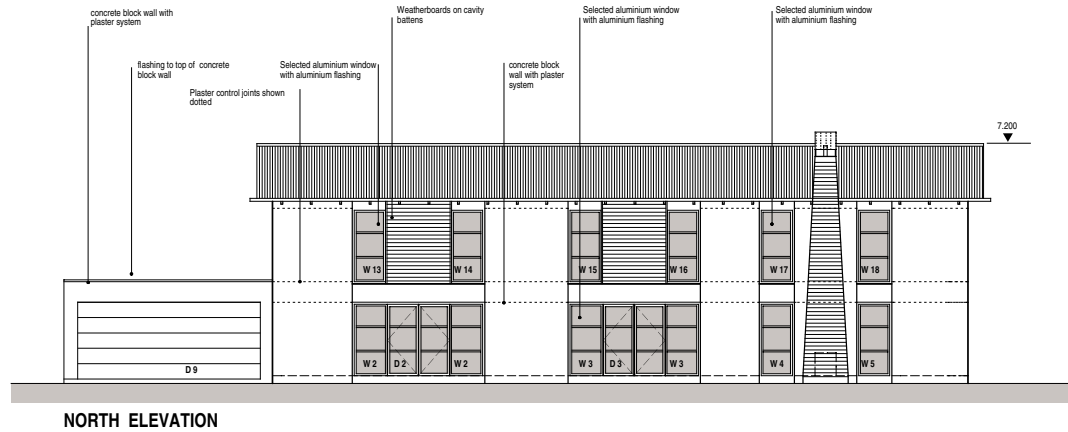
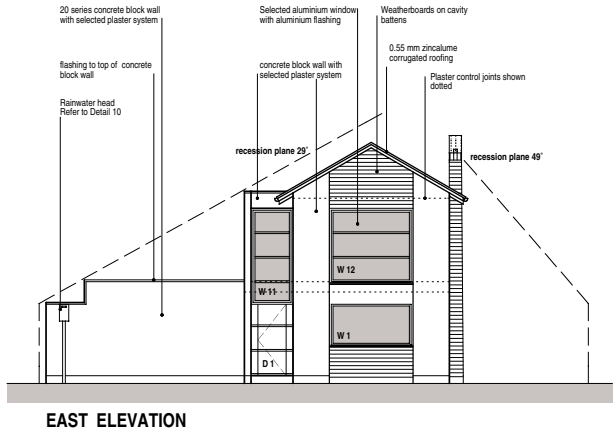

CLIENT _____
 CONTRACTOR _____
 CONSULTANTS _____
**PROPOSED NEW DWELLING
 ABC STREET**

ELEVATIONS

SCALE _____
 DATE 28 February 06
 JOB No. 07123
 DRAWN _____
 CHECKED _____
 STATUS Construction
 DRAWING No. A05 REVISION (B)

6.5 Sections

The purpose of sections is to show all vertical and horizontal building elements and the relationship of the ground, floors, ceilings and roofs to each other, and to detail structural framing and other construction elements.

Additional information

Sections and details can be combined on the same drawing, if appropriate. This can often improve clarity for those using the drawings, especially if details are shown in their relative position to an accompanying cross-section.

You can use sections to more accurately locate details. When of a suitable scale, sections can be used to detail elements such as staircases, decks and balustrades.

DRAWING TYPE (Note 1)	RECOMMENDED SCALE	RECOMMENDED DETAIL (Note 2)
Cross-sections (Note 3)	1:50 (Note 4)	<ul style="list-style-type: none"> • Ground levels and levels relative to site datum. • Wall heights. • Window and door height dimensions. • Framing sizes and treatments (or in the specification) (Note 5). • Construction details (eg, wall and floor linings). • Roof and ceiling pitches. • Floor slopes. • Location of details.

Note 1 Drawings may be combined.

Note 2 Requirements may differ where the building project is an alteration or addition to an existing building.

Note 3 The number of cross-sections provided must be adequate to show all vertical relationships. Location of cross-sections should be shown on floor plans.

Note 4 A scale of 1:20 may be used in some cases.

Note 5 Timber grades may be identified on the drawings or in the specification.

Sample only

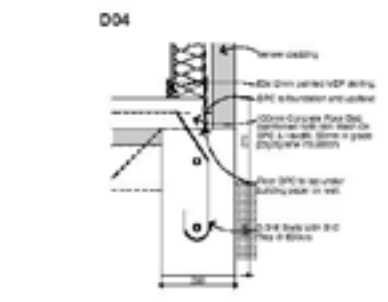
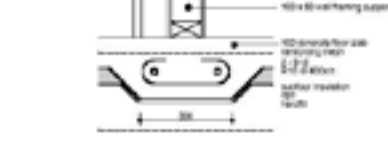
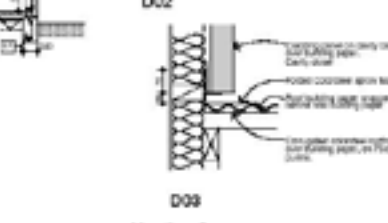
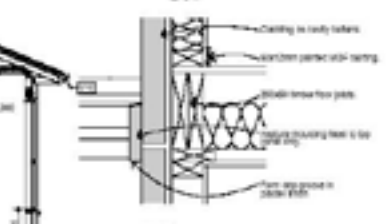
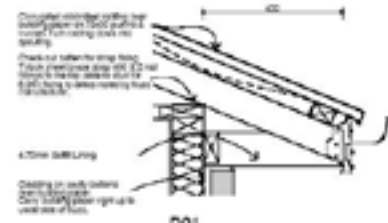
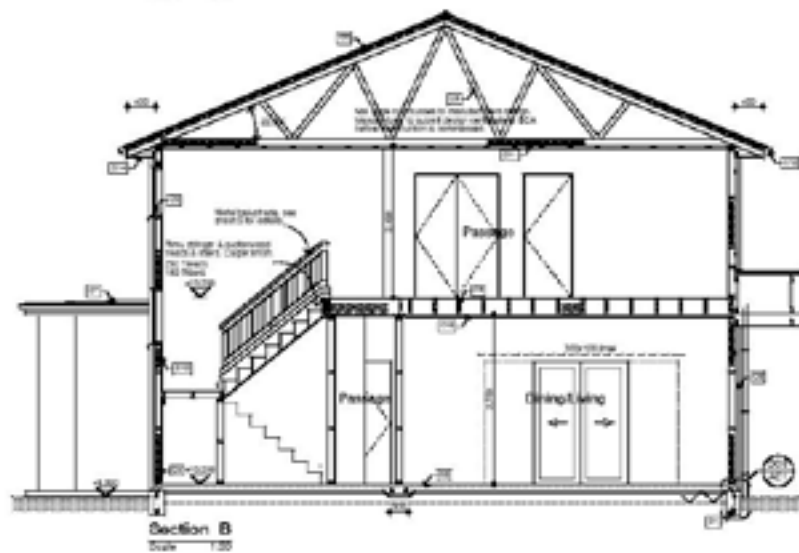
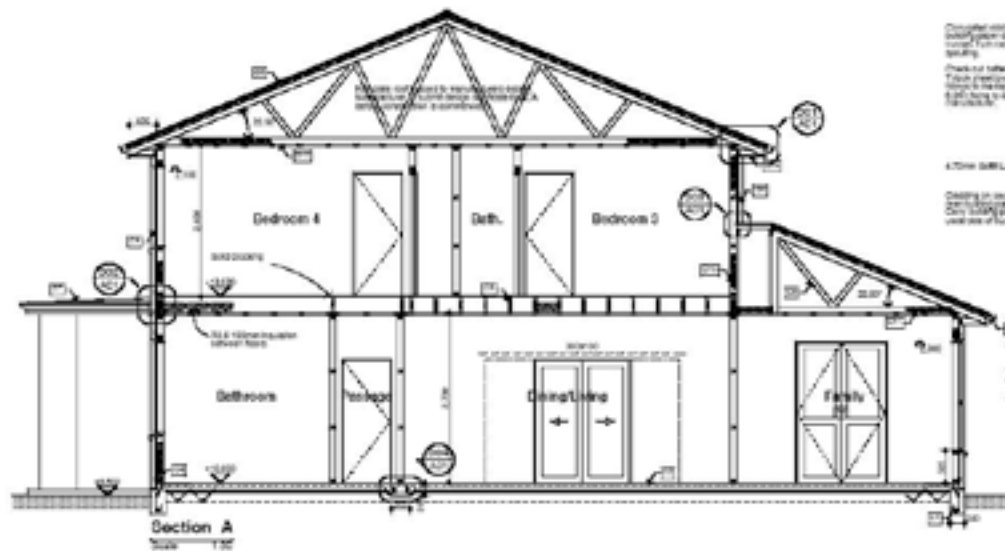

- KEY NOTES**
- D1 20mm x 40mm x 100mm
 - D2 100mm x 100mm x 100mm
 - D3 100mm x 100mm x 100mm
 - D4 100mm x 100mm x 100mm
 - D5 100mm x 100mm x 100mm
 - D6 100mm x 100mm x 100mm
 - D7 100mm x 100mm x 100mm
 - D8 100mm x 100mm x 100mm
 - D9 100mm x 100mm x 100mm
 - D10 100mm x 100mm x 100mm
 - D11 100mm x 100mm x 100mm
 - D12 100mm x 100mm x 100mm
 - D13 100mm x 100mm x 100mm
 - D14 100mm x 100mm x 100mm
 - D15 100mm x 100mm x 100mm
 - D16 100mm x 100mm x 100mm
 - D17 100mm x 100mm x 100mm
 - D18 100mm x 100mm x 100mm
 - D19 100mm x 100mm x 100mm
 - D20 100mm x 100mm x 100mm
 - D21 100mm x 100mm x 100mm
 - D22 100mm x 100mm x 100mm
 - D23 100mm x 100mm x 100mm
 - D24 100mm x 100mm x 100mm
 - D25 100mm x 100mm x 100mm
 - D26 100mm x 100mm x 100mm
 - D27 100mm x 100mm x 100mm
 - D28 100mm x 100mm x 100mm
 - D29 100mm x 100mm x 100mm
 - D30 100mm x 100mm x 100mm
 - D31 100mm x 100mm x 100mm
 - D32 100mm x 100mm x 100mm
 - D33 100mm x 100mm x 100mm
 - D34 100mm x 100mm x 100mm
 - D35 100mm x 100mm x 100mm
 - D36 100mm x 100mm x 100mm
 - D37 100mm x 100mm x 100mm
 - D38 100mm x 100mm x 100mm
 - D39 100mm x 100mm x 100mm
 - D40 100mm x 100mm x 100mm
 - D41 100mm x 100mm x 100mm
 - D42 100mm x 100mm x 100mm
 - D43 100mm x 100mm x 100mm
 - D44 100mm x 100mm x 100mm
 - D45 100mm x 100mm x 100mm
 - D46 100mm x 100mm x 100mm
 - D47 100mm x 100mm x 100mm
 - D48 100mm x 100mm x 100mm
 - D49 100mm x 100mm x 100mm
 - D50 100mm x 100mm x 100mm
 - D51 100mm x 100mm x 100mm
 - D52 100mm x 100mm x 100mm
 - D53 100mm x 100mm x 100mm
 - D54 100mm x 100mm x 100mm
 - D55 100mm x 100mm x 100mm
 - D56 100mm x 100mm x 100mm
 - D57 100mm x 100mm x 100mm
 - D58 100mm x 100mm x 100mm
 - D59 100mm x 100mm x 100mm
 - D60 100mm x 100mm x 100mm
 - D61 100mm x 100mm x 100mm
 - D62 100mm x 100mm x 100mm
 - D63 100mm x 100mm x 100mm
 - D64 100mm x 100mm x 100mm
 - D65 100mm x 100mm x 100mm
 - D66 100mm x 100mm x 100mm
 - D67 100mm x 100mm x 100mm
 - D68 100mm x 100mm x 100mm
 - D69 100mm x 100mm x 100mm
 - D70 100mm x 100mm x 100mm
 - D71 100mm x 100mm x 100mm
 - D72 100mm x 100mm x 100mm
 - D73 100mm x 100mm x 100mm
 - D74 100mm x 100mm x 100mm
 - D75 100mm x 100mm x 100mm
 - D76 100mm x 100mm x 100mm
 - D77 100mm x 100mm x 100mm
 - D78 100mm x 100mm x 100mm
 - D79 100mm x 100mm x 100mm
 - D80 100mm x 100mm x 100mm
 - D81 100mm x 100mm x 100mm
 - D82 100mm x 100mm x 100mm
 - D83 100mm x 100mm x 100mm
 - D84 100mm x 100mm x 100mm
 - D85 100mm x 100mm x 100mm
 - D86 100mm x 100mm x 100mm
 - D87 100mm x 100mm x 100mm
 - D88 100mm x 100mm x 100mm
 - D89 100mm x 100mm x 100mm
 - D90 100mm x 100mm x 100mm
 - D91 100mm x 100mm x 100mm
 - D92 100mm x 100mm x 100mm
 - D93 100mm x 100mm x 100mm
 - D94 100mm x 100mm x 100mm
 - D95 100mm x 100mm x 100mm
 - D96 100mm x 100mm x 100mm
 - D97 100mm x 100mm x 100mm
 - D98 100mm x 100mm x 100mm
 - D99 100mm x 100mm x 100mm
 - D100 100mm x 100mm x 100mm

PROPOSED NEW DWELLING	
ABC STREET	
CHRISTCHURCH	
Section / Details	
SCALE	1:50 / 1:10
DATE	02 February 18
JOB No.	010
DESIGN	DR
CHECKED	MR
BY/NO	CONSTRUCTION
DESIGNED BY	CONSTRUCTION
A/01	(A)

6.6 Construction details

The purpose of construction details is to fully describe junctions and interfaces between and within all major building elements. You need to provide details for all relevant Building Code clauses, including structural and weatherproofing design, and all necessary information about the construction needed.

Additional information

You can combine sections and details on the same drawing. This can improve clarity, especially if details are shown in their relative position to an accompanying cross-section.

A range of scales from 1:10 to 1:2 may be justified, depending on the complexity of the material relationships within the element being described. The detail needs to identify critical dimensions.

It's sensible to group the details of common materials on the same drawing, such as all exterior window and door details.

DRAWING TYPE (Note 1)	RECOMMENDED SCALE	RECOMMENDED DETAIL (Note 2)
Details	1:5 (Note 3)	<p>The extent and number of details will vary significantly depending on the size and complexity of the building design. However, the following might constitute minimum requirements.</p> <ul style="list-style-type: none"> • Structural elements, junctions and fixings. • Penetrations through exterior walls and roofs. • Window and door head/sill/jamb. • Cladding junctions (horizontal and vertical). • Expansion and movement joints. • Wall/roof junctions. • Bottom plate/cladding overhang. • Soffit and parapet details. • Retaining wall details. • Tanking and damp-proofing, cross-sections and details. • Deck or pergola connections to main structure. • Stairs showing rise/going/pitch/handrails. • Deck balustrades and handrails, layouts and fixings. • Fire separation junction and penetration details.

Note 1 Drawings may be combined.

Note 2 Requirements may differ where the building project is an alteration or addition to an existing building.

Note 3 Larger or smaller scales may be justified in some cases, depending on circumstances, to show sufficient detail.

Sample only

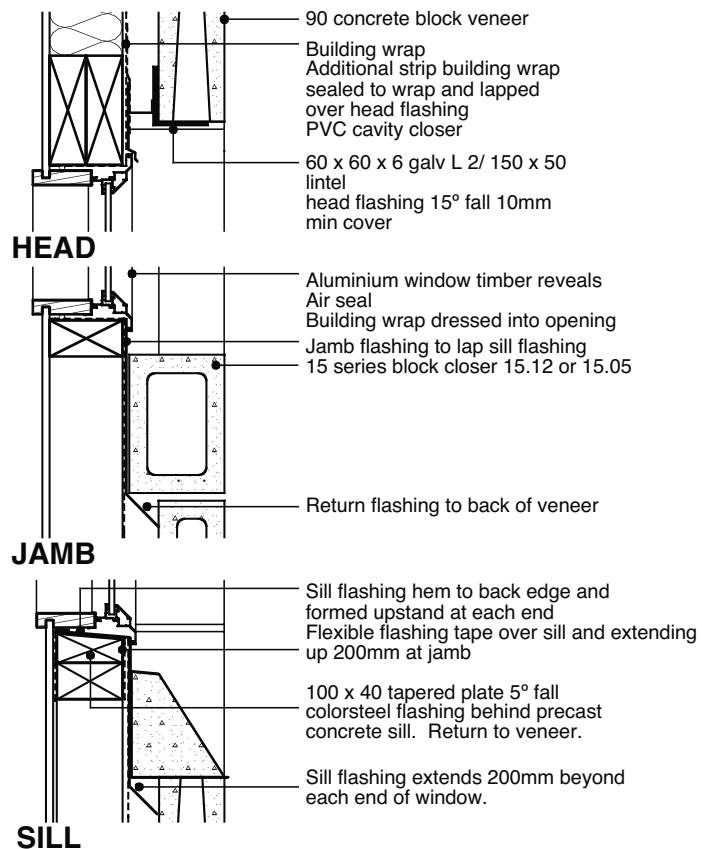

DETAILS
Scale 1:10

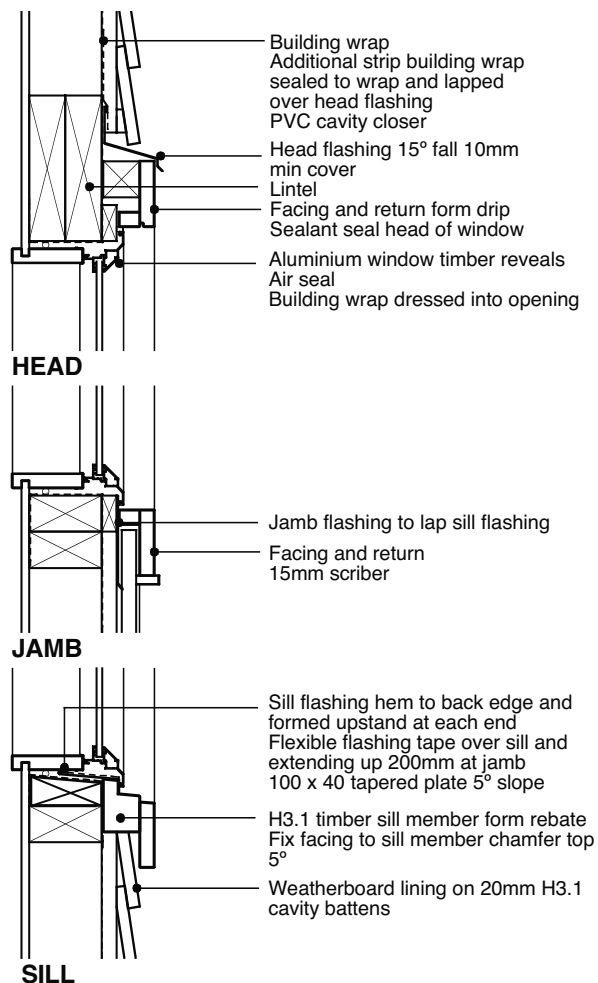

PROPOSED NEW DWELLING
ABC STREET
City field empty

Window Details

SCALE	1:5
DATE	22/11/05
JOB No.	0712
STATUS	CONSTRUCTION
DRAWING No.	REVISION

D07

A

6.7 Additional drawings

It may not always be possible to adequately describe or show clearly the full level of detail required on the drawings discussed in sections 6.1 to 6.6 of this guide. You may need to provide additional drawings, such as the following.

LOCATION PLAN

A location plan is a high-level 'bird's eye view' of the area surrounding the proposed construction work. It shows the location of the proposed work in relation to adjoining streets or properties. These plans are particularly useful in rural or remote locations, or multi-unit residential complexes.

FLOOR FRAMING PLAN

This is required when floor joists do not follow a regular pattern, or specific structural requirements need to be shown. It can include:

- floor beam and joist layouts and sizes, including blocking, trimmer joists and boundary joists
- drawings of specialty engineered timber and timber/steel products (where these are detailed, calculations and data sheets should be included in the consent documentation).

ROOF/CEILING FRAMING PLAN

This is needed where a range of roof and ceiling forms are involved or complex junctions occur. It can include:

- a plan layout of all roof and ceiling framing members and seating of trusses and beams
- drawings of timber trusses, and proprietary timber and timber/steel (where these are detailed, calculations and data sheets should be included in the consent documentation).

ROOF PLAN

This is needed for complex roof forms, or where a number of different roofing types are used. It can include:

- details of roof falls (direction and slope)
- location and size of all rainwater heads, scuppers, internal gutters, spouting and downpipes (including calculations).

ELEVATIONS OF EXTERIOR OPENINGS

These are needed when window and door elevations are not clearly shown on the wall elevations. It can include:

- 1:50 elevations of each exterior window and door element layout
- details of glazing types and window opening types, or reference to the specification.

PROTECTION OF ADJOINING PROPERTIES

The building consent authority may require information on how adjoining properties will be protected from the work being undertaken on site (for example, surface water control, temporary retaining wall, site hoarding or fencing).

DETAILS OF SPECIALIST INSTALLATIONS

When these are needed, they can include:

- details of proprietary installations, such as suspended concrete floors, precast concrete panels, timber trusses, engineered timber products and steel bracing frames
- drainage and plumbing schematics for buildings that are more than one storey or where plumbing designs are complicated.

WET AREA DETAILS

These are needed to detail wall and floor finishes in wet areas, such as kitchens, bathrooms or laundries.

7.0 Related issues

7.1 SOLID-FUEL HEATERS

Where solid-fuel heaters are proposed as part of the building work, the plans and specifications need to identify the:

- appliance by brand and model
- proposed location of the appliance
- flue type
- location, flashing and installation details
- height of the top of the flue relative to ridge lines and windows.

The joint Australian and New Zealand Standard AS/NZS 2918: 2001 Domestic Solid Fuel Burning Appliances – Installation is cited in C/AS1 as an Acceptable Solution for installing domestic solid-fuel-burning appliances.

The Resource Management Act 1991 sets out requirements for fireplace emissions. Information on appliances that have been tested to meet emission requirements is available on www.mfe.govt.nz/laws/standards/woodburners

7.2 THE FENCING OF SWIMMING POOLS ACT 1987

Where building work includes constructing a swimming pool (as defined by the Fencing of Swimming Pools Act 1987), the pool must be fenced to comply with the requirements of Clause F4 Safety from Falling of the Building Code. Fencing and pool construction details establishing compliance will need to be included with the consent documentation.

Any new pool, as defined in the Fencing of Swimming Pools Act 1987, must comply with that Act. Where a property already has a pool, it also must be fenced to comply with the Act. The Act also applies to spa pools (including those with lockable lids).

7.3 VARIATIONS AND AMENDMENTS

When applying to amend a building consent, the application should include details of what was originally approved and how it will be changed. It must also demonstrate that the new proposal complies with the Building Code and will not affect other works' compliance with the Code.

All variations to a building project that relate to the Building Code must be notified to the building consent authority, so it can approve and record them. The nature of the change will influence the process that needs to be followed to have the variation approved and recorded. Applications for amendments should be made and approved before the change takes place.

If changes are unrecorded or not approved by the building consent authority, the building consent authority may issue a notice to fix for the variation and may also refuse to issue the code compliance certificate.

7.4 MANUFACTURERS' DATA (AND BRANDED VERSUS GENERIC SPECIFYING)

Much of the information provided by product manufacturers is of a general or marketing nature. You should provide only relevant technical literature that is sufficient to show compliance with the Building Code. Providing the entire technical manual is unnecessary and inappropriate.

The building consent authority may request that you provide specific technical data from the product manufacturer, accompanied by an independent appraisal or verification that the product will meet Building Code requirements. You should attach this to the other documents submitted for building consent approval.

7.5 FACTORY-MANUFACTURED BUILDING ELEMENTS (ROOF TRUSSES AND FLOORING SYSTEMS)

Before the Building Act 2004, building consent authorities were often prepared to issue a building consent based on outline information for proposed factory-manufactured building elements, for example roof trusses and flooring systems. Sometimes this information would be supplemented with more detailed information, after fabrication and before erection on site.

The Building Act 2004 has placed more emphasis on the complete 'for construction' documentation being supplied with an application for building consent.

In many cases, designs for factory-manufactured building elements were only supplied to the builder when the goods were delivered. This is no longer considered acceptable practice.

Building consent application

Before lodging a building consent application, you should obtain a buildable design from a fabricator. This design needs to be attached to the building consent application and submitted to the building consent authority for approval.

Buildable designs show:

- proposed building elements
- proposed layout
- site-specific conditions (for example, wind zone, roof type, cladding type)
- where load-bearing walls and foundation thickenings are required
- spans
- any specific lintel/beam requirements
- the timber grade.

Buildable designs are based on industry-accepted computer design programs, which in turn are based on relevant standards. The information should also include the details of the fabricator and the design program and version used.

Construction

During the work phase, the fabricator is likely to visit the site to check all relevant measurements in order to manufacture the trusses or flooring system. The manufacturer will produce 'shop drawings', which are highly detailed drawings for the person who makes the trusses or flooring system. They will also produce a series of on-site instructions, and a layout plan for the person who erects the building elements.

Once the installation has been completed, the as-built information should be supplied to the builder, designer and homeowner, and the building consent authority for its records. The building consent authority may place a note to this effect on the building consent approval.

7.6 SERVICES PLANS

The Building Code requires that sanitary fixtures and sanitary appliances are provided with a safe and adequate water supply, and an adequate plumbing and drainage system.

At the time of the building consent application, the building consent authority will require certain information on the water supply system and the foul water and surface water (stormwater) disposal systems. It will also require documented assurance that an adequate water supply is available and that there are adequate means of disposal of both foul water and stormwater. These can be either by connections to a local council or network utility operator's system or, where these are not available, within the building site.

On-site disposal systems may require additional approvals under the Resource Management Act 1991.

Precisely how a water supply, or a waste or foul water disposal system, is to be laid out may not be apparent when you apply for a building consent. However, you should provide the location and specification of all fixtures and fittings, together with a diagrammatic layout of foul and surface water (stormwater) drainage. Schematic layouts of water or waste-water pipework are not normally needed, unless specific information is needed to confirm compliance with the Building Code.

When the project is finished, the building consent authority will ask you for an as-built drainage plan for its records.

Where on-site disposal of foul water is proposed, the means of compliance should be identified in the design summary under the heading G14.

7.7 APPRAISALS, TECHNICAL STATEMENTS, CODES OF PRACTICE, WARRANTIES AND GUARANTEES

A building consent authority may accept numerous ways of verifying a product, material or system's performance. These include:

- appraisals by specialist organisations
- test reports
- technical statements and opinions
- calculations (supported by producer statements) by designers and/or manufacturers or installers
- codes of practice from industry bodies.

The building consent authority may request copies of warranties and guarantees (under contract, or offered by product manufacturers) provided by accredited or licensed installers and manufacturers. This is in addition to specialist technical publications and the technical data provided by product manufacturers.

You and the building consent authority may choose to rely on some or all of these mechanisms to support or confirm compliance. However, the building consent authority shouldn't insist that you provide a particular approach to, or a particular means of verifying, your proposed design.

All such approaches to confirming compliance, or to supporting an alternative solution proposal, can be valid.

7.8 CALCULATIONS

When the performance of a particular building element needs to be calculated (eg, structural beams and lintels, insulation or flow rates for mechanical ventilation systems), these calculations may need to be included with the documents required for a building consent.

7.9 SMOKE ALARMS

All residential dwellings now require smoke alarms. The minimum requirement is for a battery-powered device with a silence and test button. This also applies to alterations to existing dwellings.

8.0 Application for project information memorandum and/or building consent

When applying for a building consent, you will need to apply for a project information memorandum (PIM) at the same time, if you haven't already got one. The building consent authority provides a form (Form 2) that you can use for either or both purposes.

This form asks for details about the property, the owners, who is undertaking various parts of the work and a brief description of the proposed work.

The content and wording of Form 2 has been prescribed in regulations. Building consent authorities reproduce the form and can add additional requirements, as long as the form has the same effect and is not misleading. You must fill out the application form in full and ensure it is factually correct.

You can find much of the property information from a rates demand, lease agreement, copy of the certificate of title, or from local council archive records. If you seek information from local council records, separately or as part of an application for a PIM, charges may apply.

The description of the work proposed should be clear and precise. For example:

- 'Addition of lounge, kitchen alterations and new conservatory' rather than 'Additions and alterations'.
- 'New 100 m² dwelling with two-car garaging, associated earthworks and retaining walls' rather than 'New dwelling'.

Licensed building practitioners

From November 2009 it will be necessary to provide certification from the Design Lead licensed building practitioner and to identify the Site Lead licensed building practitioner. From November 2011, it will also be necessary to identify the licensed building practitioners that will certify structure and envelope construction work. Where the construction licensed building practitioners are not known at the time of application, the building consent authority will need to be informed before the work starts. The Department will provide further guidance material on the licensed building practitioner regime.

Form 2 requires you to write a description of how your project will comply with the Building Code. You need only to provide a brief description.

Cable cars

Form 2 calls for information on 'compliance schedules' for buildings. This requirement does not relate to a stand-alone residential dwelling, unless the dwelling has a cable car attached to it or servicing it. From 2008, all buildings with cable cars will need a compliance schedule.

9.0 Building inspection requirements

The building consent authority will need to undertake inspections while the building is being built. Building consent authorities decide what inspections they need to carry out based on their evaluation of the plans, specifications and other information, including any proposed owner inspections (for example, by an engineer).

These are the more common inspections undertaken by a building consent authority.

- Pre-pour (before concrete is poured, for example, for piles, footings, slabs, in situ walls or blockwork infill)
- Tanking/waterproofing (before back-filling retaining walls, covering membranes on decks or laying tiles in wet areas such as showers)
- Pre-clad (before wrapping the building in building paper or building wrap and installing the cladding)
- Post-clad (before applying coatings to fibre cement or polystyrene systems possibly including inspections during the plastering)
- On completion of the cladding systems
- Half-high brick (where veneer is used)

- Pre-line (with insulation installed but before installing internal linings. This inspection may include checking the plumbing installation under pressure test. Where a domestic sprinkler system has been installed in your dwelling a flow test should be undertaken before fitting linings.)
- Post-line (checking bracing element fixings before plastering and decorating)
- Drainage (before filling in trenches and covering the in-ground pipework. Pipework should be under test for this inspection; drainage testing can include smoke, air or water testing.)
- Final inspection for plumbing, building and drainage work (once the work described in the building consent is completed)

This list is not exhaustive. Different building consent authorities have different inspection requirements, depending on the size and complexity of each project.

You will find it useful to have an understanding of what inspections are needed and when they are needed. Missed inspections may prevent a building consent authority from being able to establish full compliance with the building consent, therefore preventing them from issuing the code compliance certificate.

It is not the role of the building consent authority to control the quality of the building work beyond ensuring it complies with the Building Code, or to act as a clerk of works (site supervisor or foreman) on the project.

When booking an inspection, give the building consent authority as much notice as possible. Provide information about the type of inspection required, a contact name and phone number, building consent number, and a clear address. If the property is isolated or hard to find, give adequate directions.

When on site, a building inspector will need copies of the approved building consent documentation and other approvals. Ensure the site is clean, tidy and safe, and that a person with adequate knowledge of the project is on site to answer any questions.

10.0 Project planning

10.1 RESOURCE MANAGEMENT AND OTHER NON-BUILDING ACT REQUIREMENTS

It is possible to obtain a building consent where the work complies with the Building Code, but does not comply with other legal requirements such as a district plan or the Resource Management Act 1991. The work may not be able to proceed if there is non-compliance and a resource consent can't be or hasn't been obtained.

The Building Act also provides for the building consent authority to withhold the code compliance certificate if you haven't paid development contributions.

During the planning and design phase of the project, you should contact your territorial authority and discuss any relevant rules and resource consent or other requirements. Pay particular attention to site coverage, building height, and other bulk and location requirements. It may be possible to alter the design to ensure it complies with the Resource Management Act 1991. The earlier you are aware of this the better. Other matters you can discuss with the territorial authority include approvals for connections to local council services (stormwater, sewer).

You need to give special consideration to the requirements of other acts when building:

- on steep slopes
- on waterfront or riverside locations
- close to adjoining properties
- close to the front boundary with the street
- over territorial authority services or network utility operators' systems
- under overhead transmission lines
- close to airports or ports
- driveways close to street corners
- driveways off busy main roads
- where no drive-on access is available
- on sites requiring trees to be cleared
- in heritage or character precincts
- in or on land that may be contaminated
- in or on land subject to a natural hazard (you should identify these on the site or location plan if you know about them before applying for your building consent).

You may find it useful to apply for a project information memorandum (PIM) before developing full detailed drawings. The PIM gives early notice of special requirements, including any development contributions you need to pay.

The PIM can provide other useful information that will help you comply with the Building Code.

The project manager or designer engaged to manage the project may handle these non-Building-Act-related matters for you.

10.2 PRODUCT MANUFACTURERS' INFORMATION

Information provided by manufacturers, their agents or importers is often intended for marketing purposes. Such information may not be sufficient to satisfy the building consent authority that the product would meet specific requirements of the Building Code.

Product manufacturers

Further guidance for product manufacturers on the recommended form and content of information on branded products is set out in AS/NZS 1388 Guidelines for Technical Information for Building and Construction Products.

10.3 ROOF TRUSS DESIGN

When seeking a buildable roof truss design from a fabricator, the designer should provide the following information so the detailer can understand what the roof will look like and how it will be supported.

- Dimensioned drawings showing elevations, floor plans, cross-sections and foundation plans
- Details of barge, fascia and soffit construction
- Ceiling form and construction (for example, plasterboard on timber battens)
- Wind zone, corrosion zone, earthquake zone and snow loads (where applicable)
- Any additional loads that may be imposed on the roof structure (in other words, ventilation systems, solar water heaters, storage in the roof space, large light fittings, or lifting cradles for people with disabilities)
- Proposed connectors from trusses to the framing top plate
- Any point loads
- Relevant information from the specification on the type of roof cladding (for example, pressed steel tiles are light and clay tiles are heavy) and its support (for example, purlins or sarking)
- Roof pitch

A truss detailer consulted early in the design process can provide an easily built design. They may also provide suggestions that would ensure a simpler and cheaper roof, and clarify any downstream effects on walls and foundations.

11.0 Glossary of terms

BUILDING ACT 2004

The Building Act 2004 is the Act of Parliament that governs building work in New Zealand.

BUILDING CONSENT

Building consents give approval to undertake building work. When a building consent is issued, the work must be undertaken in accordance with that consent.

BUILDING CONSENT AUTHORITY

The Building Act 2004 introduced a new entity to undertake building consent and inspection functions called a building consent authority. It can be either part of a territorial authority (local council) or regional authority, or be a private company. All building consent authorities will need to be registered and accredited to perform building control functions. In addition, they will be subject to regular external independent accreditation audits to help ensure they can adequately undertake their building control functions to certain standards.

For more information see the Department of Building and Housing's website (www.dbh.govt.nz).

DEVELOPMENT CONTRIBUTION FEE

Territorial authorities can charge a development contribution fee to those applying for a building consent. These fees help the territorial authority develop the infrastructure to support new developments in the area.

LICENSED BUILDING PRACTITIONER

From 30 November 2007, licence classes will be introduced for people working in certain areas of design and building work. To get a licence, people will have to show that they meet the national standard for the licence class they apply for.

People can apply to become licensed and have their name listed on a public register. Members of the public can view this register and use it to choose competent building and design practitioners who have demonstrated they meet the national standards.

From 30 November 2009 onwards, certain types of work will need to be undertaken or supervised by licensed building practitioners.

NEW ZEALAND BUILDING CODE

The New Zealand Building Code contains 35 technical clauses and sets minimum performance standards that buildings must comply with. The Building Code Compliance Documents can be downloaded from the Department of Building and Housing's website (www.dbh.govt.nz).

NEW ZEALAND STANDARDS

Standards New Zealand provides a variety of Standards for the building industry, covering issues such as construction, testing, advice and manufacturing. These can be obtained from Standards New Zealand (www.standards.co.nz).

NOTICE TO FIX

This is a legal notice issued by a building consent authority when it has identified breaches of the Building Act, such as carrying out building work not in accordance with a building consent.

Failing to comply with a notice to fix is an offence under the Building Act, and can incur an initial fine up to \$200,000, plus \$20,000 for every day or part day during which the offence continues.

PLANS AND DRAWINGS

The Standard NZMP 4212: 1998 Glossary of Building Terms, published by Standards New Zealand, defines a 'plan' as:

The top view or horizontal section of an object as projected in orthographic projection. Anything drawn or represented on a horizontal plane, as a map or as the horizontal section of a building.

NZMP separately defines a 'drawing' as:

- (1) (Working) Drawings to scale or dimensioned for the purpose of guiding and controlling the making of parts of the work as distinct from a pictorial presentation showing only the general form of the work.
- (2) (Detail) A large scale drawing to give information which cannot be shown on small scale drawings or adequately described in the specification.

PROJECT INFORMATION MEMORANDUM (PIM)

A project information memorandum is issued by a territorial authority. It details any information the territorial authority has that may affect your proposed project, so it's a useful document to get before completing design work.

TERRITORIAL AUTHORITY

Territorial authorities are commonly known as local councils. They undertake the building control functions required by the Building Act 2004.

WEBSITES THAT PROVIDE FURTHER INFORMATION

www.dbh.govt.nz
www.consumerbuild.org.nz

TO CONTACT THE DEPARTMENT OF BUILDING AND HOUSING

Freephone: 0800 242 243
Website: www.dbh.govt.nz

Published in January 2007 by
Department of Building and Housing
PO Box 10-729
Wellington, New Zealand

This document is also available
on the Department's website:
www.dbh.govt.nz

ISBN: 0-478-29750-5 (book)
ISBN: 0-478-29751-3 (website)

